

## QUICK INSTALLATION GUIDE



### KFA2

4-wire TDR-Sensor with single rod, wire rope or coaxial probe for continuous level measurement and point level detection in liquids and light solids, with analog and switching output.

### DOCUMENT DESCRIPTION

This quick installation guide gives instructions for mounting, wiring, and basic configuration of KFA2. This will be sufficient to achieve a fully functional sensor in most applications. For further details and advanced configuration of KFA2, please contact your local distributor or KFA directly.

### INSTALLATION PROCEDURE

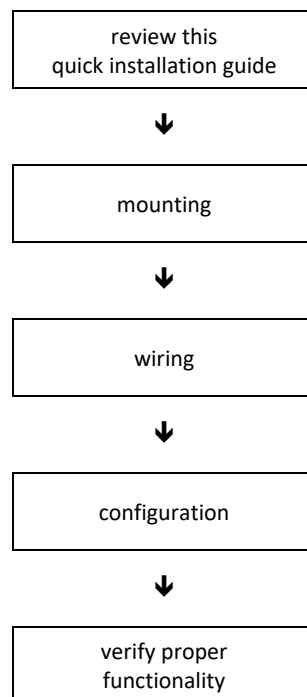

CONTACT  
KFA SARL

PHONE +33 (603) 25 35 07  
E-MAIL QUATTLAENDER@KFA-SARL.FR  
WEB WWW.KFA-SARL.FR

Figure 1: mounting

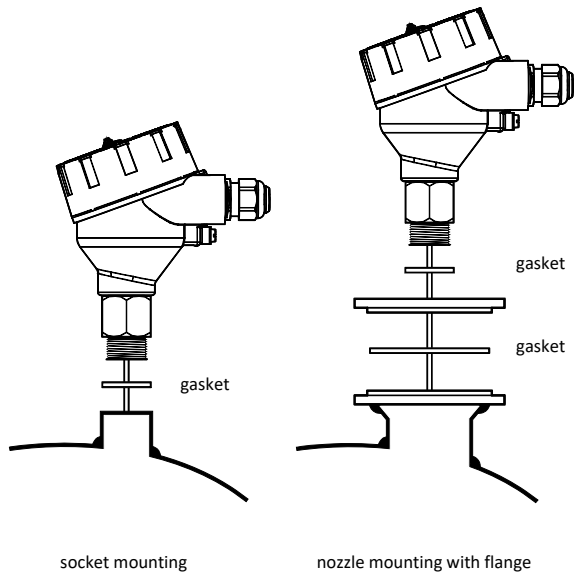

Figure 2: extended temperature option



Figure 3: single rod probe, PTFE coated



## MOUNTING

In case KFA2 is delivered with a detached probe, attach the probe onto the small threaded stud below the hexagon. Ensure that you mount the counter nut first to secure the probe connection: it has to be interlocked against the probe, NOT against the plastic of the feedthrough (this would result in sheering off the small threaded stud; permanently damaging the sensor).

KFA2 is mounted vertically to the tank via its connection thread, which is screwed directly into a standard threaded tank connection, i.e. weld-in socket, or it can be screwed into a flange, which is then connected to a tank nozzle. KFA2 should not be welded directly into the tank. Neither should flanges be welded onto KFA2. Welding on the metal parts of KFA2 will cause serious damage to the sensor.

Do not lift or handle KFA2 by its probe; this can cause excessive stress on the probe connection. KFA2 should be handled by the hexagon or the lower section of the housing. Do not screw in KFA2 by its housing; it should be tightened only via its hexagon (wrench size 32mm).

Tighten the coaxial probe only at its lower hexagon; the upper hexagon of the coaxial probe is not needed for mounting.

The customer has to ensure proper sealing of the sensor connection; based on his process conditions like temperature, pressure and resistance against his process liquids and atmosphere.

G thread connections require a suitable gasket for pressure-tight joints.

The G3/4A connection thread of KFA2 is supplied with a gasket made of Klingersil C-4400, thickness 2mm. The suggested tightening torque for this thread size, this type of gasket, and a process pressure of max. 40bar is 25Nm (maximum permissible torque: 45 Nm).

For NPT thread connections, pressure-tight joints require a sealant directly on the threads.

## EXTENDED TEMPERATURE RANGE

KFA2 with the extended temperature option must be properly included into the tank insulation to prevent excessive temperatures at the sensor housing due to thermal radiation or convection, as well as prevention of condensate formation. However, the insulation layer should not reach higher than the hexagon nut; the cooling fins of the radiator-style temperature extension have to be outside the insulation in order to function properly. If necessary, adjust the height of the mounting socket or nozzle accordingly.

## PTFE COATED SINGLE ROD PROBE

PTFE coated probes must be handled carefully to prevent damage to the coating.

For detailed instructions how to mount a PTFE coated KFA2, please contact your local distributor or KFA directly.

Figure 4: mounting considerations

| SINGLE ROD / WIRE ROPE PROBE                     |     |        |
|--|-----|--------|
| COAXIAL PROBE                                    |     |        |
| nozzle diameter                                  | ..1 | >50mm  |
| nozzle height                                    | -   | <300mm |
| clearance to tank wall or other internal objects | -   | >100mm |
| clearance between probe end and tank bottom      | -   | >2mm   |
| diameter of bypass chamber / stilling well       | ..2 | >25mm  |

- = no restrictions

<sup>1</sup> enough diameter to fit in the coaxial tube (Ø17,2mm)

<sup>2</sup> enough diameter to fit in the coaxial tube (Ø17,2mm) and enough room around the probe for the liquid to flow in and out of the bypass chamber / stilling well

## MOUNTING CONSIDERATIONS

The probes should be installed so that they are not directly impacted by liquids flowing out of the filling inlet.

They should neither touch nor sway towards other objects inside the tank or the tank/nozzle walls; e.g. by agitator swirls. In applications with very strong fluid movements, which can also cause excessive lateral force on the probe, it is recommended to anchor the probe. The anchoring fixtures are customer supplied.

For further details about mounting KFA2 or if you would like to anchor the probes, please contact your local distributor or KFA directly.

The single rod probe is suitable for a very wide range of applications in liquids, but the signal has a wider detection radius around the rod. Thus, it is more responsive for measurement signal disturbances which can be easily overcome by observing a few mounting considerations (see Fig. 4) and making simple configuration adjustments to the sensor; in most cases it is enough to activate and utilize the powerful disturbance signal suppression features of KFA2. However, those work most efficiently on stationary interference targets like tall and narrow nozzles or close-by objects. In case that non-stationary interference targets close to the single rod probe, like slowly rotating agitator blades, cause problems with the measurement, it is recommended to use the coaxial probe.

The single rod probe is also the recommended probe type for mounting KFA2 into bypass chambers or stilling wells. In this case, plastic centering disks are needed to prevent the probe from contacting the wall. Please contact your local distributor or KFA directly for further details.

The wire rope probe is recommended for installations in solids, tall tanks and where limited headroom is available. Its performance characteristics and mounting considerations are similar to the single rod probe.

In addition, please consider the following advice when using KFA2 in solid applications:

- The bulk solid inside the tank or silo can exert a considerable tensile load on the wire rope probe, depending on properties of the bulk solid, tank dimensions and covered probe length (see Fig. 5). This can lead to considerable downwards pulling forces on the tank roof, which has to be able to withstand the max. tensile load of KFA2: 5kN
- It is recommended that the tank be empty during installation. This ensures that the probe hangs down straight and does not get entangled. After installation also regularly check if the wire rope probe got entangled or unbraided
- Some bulk solids easily form build-up on the tank wall or on internal structures. This will interfere with the measurements. Choose a mounting position where the wire rope probe is not in contact with, or close to, such product build-up

Figure 5: approx. pulling forces [kN]

| MATERIAL             | COVERED PROBE LENGTH |     |     |     |     |     |     |     |     |
|----------------------|----------------------|-----|-----|-----|-----|-----|-----|-----|-----|
|                      | 6m                   |     |     | 12m |     |     | 20m |     |     |
|                      | TANK Ø               |     |     |     |     |     |     |     |     |
|                      | 3m                   | 6m  | 9m  | 3m  | 6m  | 9m  | 3m  | 6m  | 9m  |
| Wheat                | 0,7                  | 0,8 | 0,9 | 2   | 2,7 | 3   | 4,1 | -   | -   |
| Corn                 | 0,6                  | 0,7 | 0,8 | 1,8 | 2,4 | 2,7 | 3,7 | -   | -   |
| Rice                 | 0,5                  | 0,7 | 0,7 | 1,5 | 2,1 | 2,4 | 2,8 | 4,5 | -   |
| Flour                | 0,3                  | 0,4 | 0,4 | 1,1 | 1,3 | 1,5 | 2,4 | 3,3 | 3,7 |
| Sugar                | 0,7                  | 1   | 1   | 1,9 | 2,8 | 3,4 | 3,4 | -   | -   |
| Silica sand          | 1,1                  | 1,4 | 1,5 | 3,2 | 4,5 | -   | -   | -   | -   |
| Cement               | 1,2                  | 1,5 | 1,7 | 3,2 | 4,7 | -   | -   | -   | -   |
| Alumina              | 0,9                  | 1,1 | 1,3 | 2,3 | 3,5 | 4,2 | 4,3 | -   | -   |
| Phosphate fertilizer | 1,8                  | 2,3 | 2,6 | 5   | -   | -   | -   | -   | -   |
| Fly ash              | 1                    | 1,3 | 1,4 | 2,5 | 3,9 | 4,7 | 4,7 | -   | -   |
| Coal dust            | 0,7                  | 0,9 | 1   | 1,8 | 2,7 | 3,3 | 3,3 | -   | -   |
| Plastic pellets      | 0,4                  | 0,5 | 0,5 | 1   | 1,5 | 1,7 | 1,9 | 3,2 | 4   |

- = exceeds the max. tensile load of KFA2: 5kN. In this case use KFA3

Above figures are guidelines to estimate the approx. pulling forces from free-flowing solids acting on a suspended 4mm wire rope probe without any anchoring in a metal tank with smooth walls

- For anchoring the wire rope probe in solid applications, please contact your local distributor or KFA directly

The coaxial probe does not have restrictions regarding mounting position, tank connection, and proximity to the tank wall or other objects inside the tank.

The coaxial probe is recommended for installing KFA2 into a non-metallic tank or open pit. If that is not possible, single rod or wire rope probes can be used when KFA2 is mounted into at least a DN50 metal flange or screwed into a metal sheet with at least  $\varnothing 150\text{mm}$ .

Figure 6: cable entries

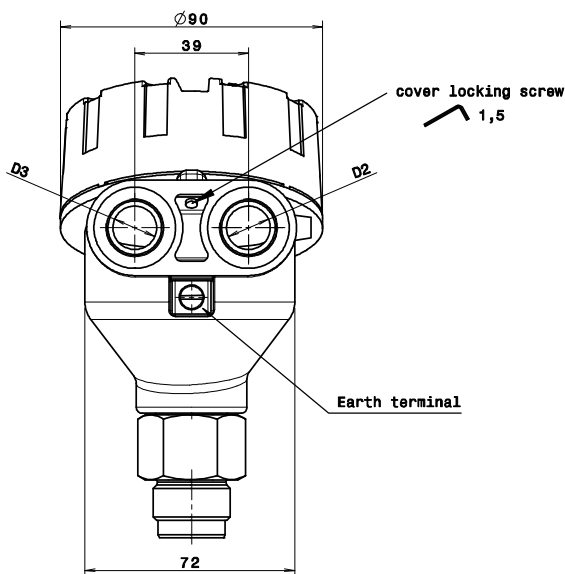

#### CABLE ENTRIES AND CABLE GLANDS

The housing has two cable entries and can be ordered with assembled standard screw plugs and cable glands. Nevertheless, the customer has to confirm the suitability of those cable glands for his specific application requirements and cabling; and replace them when necessary.

Both cable entries can be fitted with cable glands or suitable conduit systems. If only one cable gland is fitted, it is recommended to use cable entry D2 (see Fig. 6). Then cable entry D3 has to be closed with a suitable screw plug.

IP68-rated screw plugs and cable glands have to be properly sealed and have to be properly tightened around cable of suitable type and diameter to ensure the IP68 rating of the housing.

Cable entries with metric threads can be sealed by mounting the suitable screw plug or cable gland with matching rubber washers underneath.

Cable entries with NPT threads require a sealant directly on the thread of the screw plug or cable gland.

For M20x1,5 cable entries, KFA2 comes assembled with:

- 1 x cable gland M20x1,5, IP68, nylon PA66, for non-armoured cable  $\varnothing 5...9\text{mm}$ , with EPDM washer, max. tightening torque 6Nm on all hexagons, wrench size 24mm. For protection during shipment it is closed with an EPDM sealing plug which has to be removed for cabling
- 1 x screw plug, IP68, M20x1,5, nylon PA66, with EPDM washer

For 1/2" NPT cable entries, KFA2 comes assembled with:

- 2 x screw plug, 1/2" NPT, PE-LD. They are not IP68 and are only for housing protection during shipment. They have to be replaced by the customer

When wiring with shielded or armoured cable, suitable cable glands have to be used. The contact between the metal housing and the shielding of the cable is made by using a suitable EMC-type cable gland. Ground the shielding of the cable only on the sensor side; not on the supply side.

Figure 7: lower sticker on the black plastic cartridge

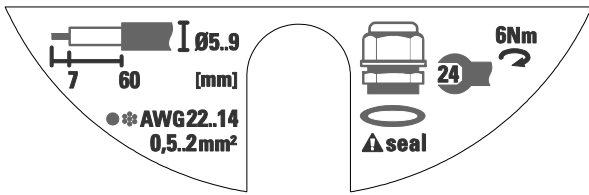

## WIRING

Verify that the power supply for the sensor is switched off.

Establish an equipotential connection (potential equalization) between the external earth terminal of KFA2 and the closest ground potential terminal of the tank.

Open the housing cover by turning it counterclockwise. It may be necessary to loosen the cover locking screw with an allen key size 1,5mm. The cover has a safety chain to prevent it from falling to the ground after being unscrewed.

The lower sticker on the black plastic cartridge inside the housing gives instructions for the standard M20x1,5 cable gland (Fig. 7). When other cable glands are being used, their details have to be observed instead.

Loosen the cable gland and pull the cable through the cable gland into the housing. Pull it far enough to have a convenient length for stripping and handling the cable.

Install cable with a drip loop outside the housing where the bottom of the loop must be lower than the cable entry of the housing.

Dismantle the cable carefully and strip the wires as indicated on the sticker.

The stripped wire ends are connected to the sensor electronic via the green screwless, cage clamp terminal block. It can accommodate stranded and solid wires 0,5...2mm<sup>2</sup> / AWG 22...14. The usage of cable end sleeves with insulation collar is not recommended.

Simply press an orange lever straight down with a small flat tip screwdriver, insert a stripped wire end into the terminal hole, and release the orange lever; the wire is now connected.

The upper sticker inside the housing illustrates the inputs and outputs if the sensor. Connect all wires accordingly, as indicated in Fig. 8.

Figure 8: wiring

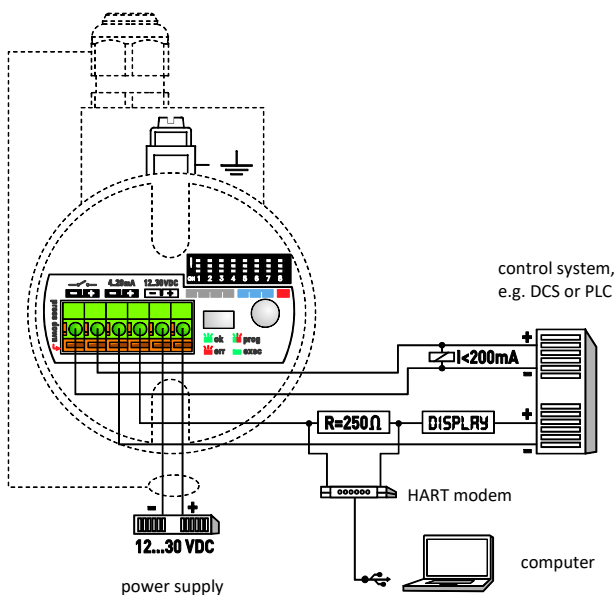

Pull the cable back, but make sure its mantle does not retract into the cable gland.

Tighten the cable gland to ensure proper sealing function.

Switch on the power supply for the sensor.

The sensor LED should start blinking green within 6 seconds after connecting the power (during this start-up time the LED is solid green). The blinking green LED indicates that the sensor is in measuring mode and working correctly.

Do not tighten the housing cover yet. Some basic configuration is still to be done...

Figure 9: control elements

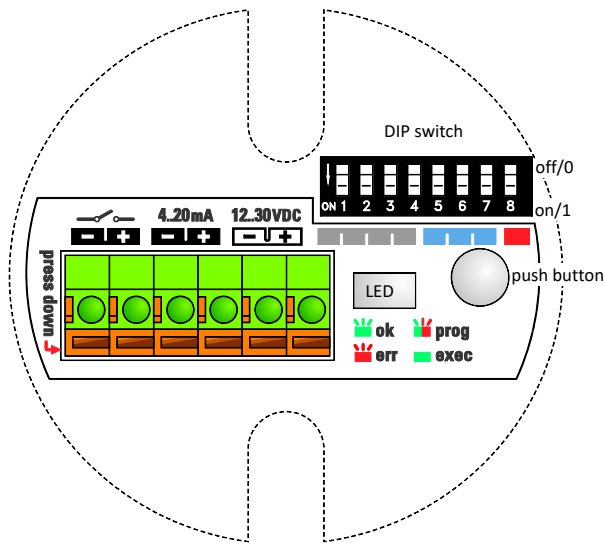

Figure 10: DIP switch settings

| DIP SWITCH POSITION |   |   |   |   |   |   |   |
|---------------------|---|---|---|---|---|---|---|
| 1                   | 2 | 3 | 4 | 5 | 6 | 7 | 8 |

| DIP SWITCH SETTINGS |   |   |   |   |   |   |   | DESCRIPTION   |
|---------------------|---|---|---|---|---|---|---|---|
| 0                   | 0 | 0 | 0 | 0 | 0 | 0 | 0 | measuring mode  |
| 0                   | 0 | 0 | 0 | 0 | 0 | 0 | 1 | configuration mode                                      |
| FUNCTION GROUP 1    |   |   |   |   |   |   |   | ANALOG CURRENT OUTPUT                                   |
| 0                   | 0 | 0 | 1 |   |   |   |   | lower range value [4mA]; span 0%                        |
| 0                   | 0 | 1 | 0 |   |   |   |   | upper range value [20mA]; span 100%                     |
| 0                   | 1 | 0 | 0 | 0 | 0 | 1 | 1 | response time 0,5s [default]                            |
| 0                   | 1 | 0 | 1 |   |   |   |   | response time 2s  |
| 0                   | 1 | 1 | 0 |   |   |   |   | response time 5s  |
| FUNCTION GROUP 2    |   |   |   |   |   |   |   | SWITCHING OUTPUT  |
| 0                   | 0 | 1 | 0 |   |   |   |   | lower threshold   |
| 0                   | 0 | 1 | 1 | 0 | 1 | 0 | 1 | upper threshold   |
| 0                   | 1 | 0 | 0 |   |   |   |   | NC [default]  |
| 0                   | 1 | 0 | 1 |   |   |   |   | NO  |
| FUNCTION GROUP 3    |   |   |   |   |   |   |   | DISTURBANCE SIGNAL SUPPRESSION                          |
| 0                   | 0 | 0 | 1 |   |   |   |   | perform disturbance signal scan                         |
| 0                   | 0 | 1 | 0 |   |   |   |   | disturbance signal scan: do not utilize                 |
| 0                   | 0 | 1 | 1 |   |   |   |   | disturbance signal scan: utilize [default] <sup>1</sup> |
| 0                   | 1 | 0 | 0 |   |   |   |   | upper dead band: short [default] <sup>2</sup>           |
| 0                   | 1 | 0 | 1 |   |   |   |   | upper dead band: medium                                 |
| 0                   | 1 | 1 | 0 | 0 | 1 | 1 | 1 | upper dead band: long                                   |
| 1                   | 0 | 0 | 0 |   |   |   |   | amplitude threshold: low [default]                      |
| 1                   | 0 | 0 | 1 |   |   |   |   | amplitude threshold: medium                             |
| 1                   | 0 | 1 | 0 |   |   |   |   | amplitude threshold: high                               |
| 1                   | 1 | 0 | 0 |   |   |   |   | coaxial probe   |
| 1                   | 1 | 0 | 1 |   |   |   |   | single rod / wire rope probe                            |
| FUNCTION GROUP 4    |   |   |   |   |   |   |   | RESET   |
| 0                   | 0 | 0 | 1 | 1 | 0 | 0 | 1 | reset to delivery configuration                         |
| FUNCTION GROUP 5    |   |   |   |   |   |   |   | MEASURE PROBE LENGTH                                    |
| 0                   | 0 | 0 | 1 | 1 | 0 | 1 | 1 | measure probe length                                    |

<sup>1</sup> for single rod and wire rope probes with a probe length [L] >5.500mm only the top 5.500mm of the probe get scanned for disturbance signals

<sup>2</sup> for single rod and wire rope probes with a probe length [L] >3.000mm the default setting is upper dead band: long

## CONTROL ELEMENTS

Basic configuration of KFA2 can be done directly on the device via three control elements: a DIP switch, a single push button and a LED for visual feedback. All settings required to get KFA2 fully operational can be performed directly on the device; or KFA2 can be ordered completely pre-configured.

All three control elements are enclosed in the black plastic cartridge inside the housing.

The DIP switch has 8 small white levers. Small numbers from 1 to 8 are printed underneath the levers: they indicate the DIP switch positions and correspond to the ones in Fig. 9.

The upper position of a lever is off/0 and the lower position is on/1. On the left side of the DIP switch is also a small indication of the on/1 state.

The off/0 and on/1 states of the DIP switch correspond to the 0/1 indications in Fig. 9.

The upper sticker on the black plastic cartridge shows three colour segments close to the DIP switch: red, grey, and blue; they correspond to the coloured rows in Fig. 10.

- red: indicates DIP switch position 8 which switches between measuring and configuration mode. Only when DIP switch position 8 is on/1, KFA2 can be configured; configuration mode is indicated by the LED blinking alternately green and red. When DIP switch position 8 is off/0, KFA2 is in measuring mode; indicated by the LED blinking green. It is only possible to enter the configuration mode when DIP switch positions 1 to 7 are off/0 before setting DIP switch position 8 to on/1; otherwise the LED is blinking red to indicate an error
- blue: indicates the DIP positions through which groups of functions are selected, e.g. all functions related to the analog current output or the switching output
- grey: indicates the DIP positions through which individual functions/configuration settings are selected

When entering into configuration mode, always start from DIP switch position 8 and move towards position 1.

When exiting configuration mode, always set back all the DIP switch positions to 0, starting from position 1 and move towards position 8.

After setting all DIP switch positions to represent the 0/1 sequence of the desired function (as described in Fig. 10), the push button has to be pressed to execute the desired function. Execution of the function is indicated by the LED remaining green until the function has been properly executed, in which case the LED returns to blinking alternately green and red.

Function groups 4 and 5 require the push button to be pressed and held for at least 10 seconds for the functions to be executed.

CONFIGURATION SINGLE ROD PROBE OR WIRE ROPE PROBE

For most standard applications, executing the three basic configuration steps below is sufficient to achieve a fully functional sensor; providing a continuous level measurement through its analog current output.

For further details and advanced configuration of KFA2, please contact your local distributor or KFA directly.

Figure 11: perform disturbance signal scan

| DIP SWITCH POSITION             |   |   |   |   |   |   |   |
|---------------------------------|---|---|---|---|---|---|---|
| 1                               | 2 | 3 | 4 | 5 | 6 | 7 | 8 |
| DIP SWITCH SETTINGS             |   |   |   |   |   |   |   |
| 0                               | 0 | 0 | 1 | 0 | 1 | 1 | 1 |
| DESCRIPTION                     |   |   |   |   |   |   |   |
| perform disturbance signal scan |   |   |   |   |   |   |   |

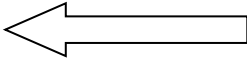

Figure 12: lower range value [4mA]; span 0%

| DIP SWITCH POSITION              |   |   |   |   |   |   |   |
|----------------------------------|---|---|---|---|---|---|---|
| 1                                | 2 | 3 | 4 | 5 | 6 | 7 | 8 |
| DIP SWITCH SETTINGS              |   |   |   |   |   |   |   |
| 0                                | 0 | 0 | 1 | 0 | 0 | 1 | 1 |
| DESCRIPTION                      |   |   |   |   |   |   |   |
| lower range value [4mA]; span 0% |   |   |   |   |   |   |   |

Figure 13: upper range value [20mA]; span 100%

| DIP SWITCH POSITION                 |   |   |   |   |   |   |   |
|-------------------------------------|---|---|---|---|---|---|---|
| 1                                   | 2 | 3 | 4 | 5 | 6 | 7 | 8 |
| DIP SWITCH SETTINGS                 |   |   |   |   |   |   |   |
| 0                                   | 0 | 1 | 0 | 0 | 0 | 1 | 1 |
| DESCRIPTION                         |   |   |   |   |   |   |   |
| upper range value [20mA]; span 100% |   |   |   |   |   |   |   |

Figure 14: measuring mode

| DIP SWITCH POSITION |   |   |   |   |   |   |   |
|---------------------|---|---|---|---|---|---|---|
| 1                   | 2 | 3 | 4 | 5 | 6 | 7 | 8 |
| DIP SWITCH SETTINGS |   |   |   |   |   |   |   |
| 0                   | 0 | 0 | 0 | 0 | 0 | 0 | 0 |
| DESCRIPTION         |   |   |   |   |   |   |   |
| measuring mode      |   |   |   |   |   |   |   |

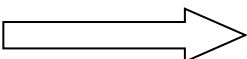

1. PERFORM DISTURBANCE SIGNAL SCAN

- KFA2 has to be mounted in its final position and the tank has to be completely empty in order to perform a disturbance signal scan
- set the DIP switch positions to the 0/1 sequence in Fig. 11 on the left; start from position 8 and move towards position 1!
- LED will blink alternately green and red
- press the push button
- LED will remain green for a few seconds while the disturbance signal scan is being performed
- once the scan is completed successfully, the LED will return to blinking alternately green and red

2. LOWER RANGE VALUE [4mA]; SPAN 0%

- fill the liquid into the tank up to the level where you want to position the lower range value [4mA]; span 0%. It is recommended that the lower range value stays within the measuring range [M]
- change DIP switch position 6 to off/0
- press the push button
- LED will remain green briefly while the lower range value setting is being executed
- once it has been executed successfully, the LED will return to blinking alternately green and red

3. UPPER RANGE VALUE [20mA]; SPAN 100%

- raise the liquid inside the tank up to the level where you want to position the upper range value [20mA]; span 100%. It is recommended that the upper range value stays within the measuring range [M]
- change DIP switch position 3 to on/1
- change DIP switch position 4 to off/0
- press the push button
- LED will remain green briefly while the upper range value setting is being executed
- once it has been executed successfully, the LED will return to blinking alternately green and red
- set all the DIP switch positions to 0 as indicated in Fig. 14 on the left; start from position 1 and move towards position 8!
- the LED will change to blinking green

Tighten the housing cover properly by turning it clockwise; make sure the cover safety chain does not tangle up. If desired, tighten the cover locking screw with an allen key size 1,5mm.

### CONFIGURATION COAXIAL PROBE

The coaxial probe has a very robust and reliable measurement performance in almost any application without further configuration. For basic configuration only the range values for the analog current output have to be set.

For further details and advanced configuration of KFA2, please contact your local distributor or KFA directly.

Figure 15: lower range value [4mA]; span 0%

| DIP SWITCH POSITION |   |   |   |   |   |   |   |
|---------------------|---|---|---|---|---|---|---|
| 1                   | 2 | 3 | 4 | 5 | 6 | 7 | 8 |
| DIP SWITCH SETTINGS |   |   |   |   |   |   |   |
| 0                   | 0 | 0 | 1 | 0 | 0 | 1 | 1 |

| DESCRIPTION                      |
|----------------------------------|
| lower range value [4mA]; span 0% |

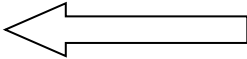

Figure 16: upper range value [20mA]; span 100%

| DIP SWITCH POSITION |   |   |   |   |   |   |   |
|---------------------|---|---|---|---|---|---|---|
| 1                   | 2 | 3 | 4 | 5 | 6 | 7 | 8 |
| DIP SWITCH SETTINGS |   |   |   |   |   |   |   |
| 0                   | 0 | 1 | 0 | 0 | 0 | 1 | 1 |

| DESCRIPTION                         |
|-------------------------------------|
| upper range value [20mA]; span 100% |

Figure 17: measuring mode

| DIP SWITCH POSITION |   |   |   |   |   |   |   |
|---------------------|---|---|---|---|---|---|---|
| 1                   | 2 | 3 | 4 | 5 | 6 | 7 | 8 |
| DIP SWITCH SETTINGS |   |   |   |   |   |   |   |
| 0                   | 0 | 0 | 0 | 0 | 0 | 0 | 0 |

| DESCRIPTION    |
|----------------|
| measuring mode |

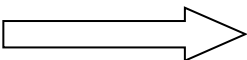

- LOWER RANGE VALUE [4mA]; SPAN 0%
  - set the DIP switch positions to the 0/1 sequence in Fig. 15 on the left; start from position 8 and move towards position 1!
    - lower the liquid inside the tank down to the level where you want to position the lower range value [4mA]; span 0%.
      - It is recommended that the lower range value stays within the measuring range [M]
    - press the push button
    - LED will remain green briefly while the lower range value setting is being executed
    - once it has been executed successfully, the LED will return to blinking alternately green and red
- UPPER RANGE VALUE [20mA]; SPAN 100%
  - raise the liquid inside the tank up to the level where you want to position the upper range value [20mA]; span 100%.
    - It is recommended that the upper range value stays within the measuring range [M]
  - change DIP switch position 3 to on/1
  - change DIP switch position 4 to off/0
  - press the push button
  - LED will remain green briefly while the upper range value setting is being executed
  - once it has been executed successfully, the LED will return to blinking alternately green and red
  - set all the DIP switch positions to 0 as indicated in Fig. 17 on the left; start from position 1 and move towards position 8!
  - the LED will change to blinking green

Tighten the housing cover properly by turning it clockwise; make sure the cover safety chain does not tangle up. If desired, tighten the cover locking screw with an allen key size 1,5mm.



Figure 18: probe length and measuring range

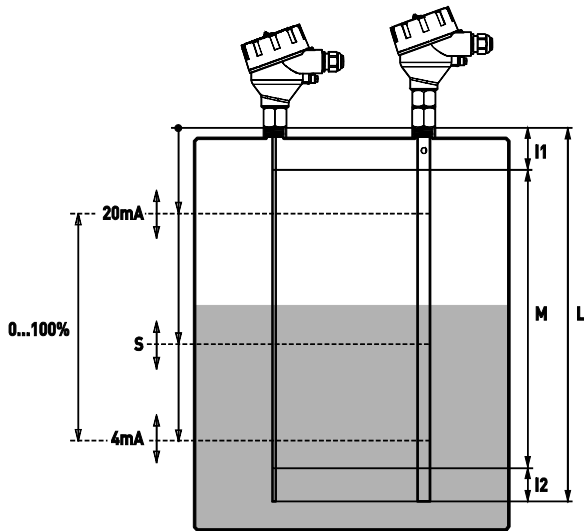

#### PROBE LENGTH AND MEASURING RANGE

The reference point for definition of the probe length  $[L]$  is always the shoulder of the connection thread. The probe length  $[L]$  is an important mechanical dimension which is needed to make sure the probe physically fits into the tank at the anticipated mounting location; it is not equal to the actual measuring range  $[M]$  of the sensor!

TDR level sensors have small inactive areas at top  $[I1]$  and bottom  $[I2]$  of the probe. Those are due to the presence of unavoidable signal disturbances at both ends of the probe. In these inactive areas the measurements are non-linear or have reduced accuracy. Therefore, it is not recommended to actually measure level within those inactive areas. Their length depends on the probe type and the reflectivity (i.e. dielectric constant) of the liquid to be measured.

The measuring range  $[M]$  of KFA2 extends between the top and bottom inactive areas of the probe; this is the area in which KFA2 will have the specified measurement performance. It is recommended that the maximum and minimum liquid levels to be measured in the tank are actually within the measuring range  $[M]$  of the sensor. The span between the lower range value  $[4mA]$  and the upper range value  $[20mA]$  of the analog current output is equal to  $0...100\%$  of your continuous level measurement reading. It is recommended that the span between those two range values stays within the measuring range  $[M]$ .

#### DISTURBANCE SIGNAL SCAN

The disturbance signal scan is a powerful disturbance signal suppression feature of KFA2. The sensor scans its entire probe length for any disturbance signals in the application that could potentially be misinterpreted as level readings, memorizes and suppresses them during operation; that way KFA2 only recognizes the actual level signals caused by the liquid to be measured.

The disturbance signal scan is intended for the single rod probe, since its signal has a wider detection radius around the rod, making it more responsive for measurement signal disturbances.

The disturbance signal scan works most efficiently on stationary interference targets like tall and narrow nozzles or close-by objects. Thus, KFA2 has to be mounted in its final position and the tank has to be completely empty in order to perform a disturbance signal scan; that will ensure a reliable identification of the actual disturbance signals only. In case that non-stationary interference targets close to the single rod probe, like slowly rotating agitator blades or streams of liquid being filled into the tank, cause problems with the measurement, it is recommended to use the coaxial probe.

Performing a disturbance signal scan is the prerequisite for utilizing this feature of KFA2.

|   |  |   |
|---|--|---|
| ELECTRICAL SPECIFICATIONS                 | 4-wire system  |   |
| Output functions                          | continuous level measurement through analog output and point level detection through switching output  |   |
| Analog output (active)                    | current output 4...20mA<br>the span between the lower range value [4mA] and the upper range value [20mA] is equal to 0...100% of the continuous level measurement reading. It is recommended that the span between those two range values stays within the measuring range [M]   |   |
| Total load resistance                     | <500Ω: HART resistor approx. 250Ω + load resistance approx. 250Ω<br>if the current output is connected to a device with an inner resistance of approx. 250Ω, then there is no additional, external HART resistor necessary. In that case, the HART modem is connected in parallel to the current output wires  |   |
| Lower range value                         | 4,0mA (span 0%)  |   |
| Upper range value                         | 20,0mA (span 100%)   |   |
| Response time                             | 0,5s [default], 2s, 5s (selectable)  |   |
| Temperature drift                         | <0,2mm/K change in ambient temperature   |   |
| Switching output DC PNP (active)          | NC [default] or NO (short-circuit protected)   |   |
| Load current                              | <200mA   |   |
| Signal voltage HIGH                       | supply voltage - 2V  |   |
| Signal voltage LOW                        | 0V...1V  |   |
| Response time                             | <100ms   |   |
| Supply voltage                            | 12...30VDC (reverse-polarity protected)  |   |
| Current consumption                       | <50mA at 24VDC (no burden)   |   |
| Start-up time                             | <6s  |   |
| Cable terminals                           | screwless, cage clamp terminal block for stranded and solid wires 0,5...2mm <sup>2</sup> / AWG 22...14<br>the usage of cable end sleeves with insulation collar is not recommended   |   |
| MEASUREMENT SPECIFICATIONS                | reference condition: dielectric constant [ε <sub>r</sub> ]=80, water surface, tank Ø1m, DN200 metal flange   |   |
| Accuracy                                  | ±3mm or 0.03% of measured distance, whichever is greatest  |   |
| Repeatability                             | <2mm   |   |
| Resolution                                | <1mm   |   |
| Probe type                                | single rod Ø6mm<br>wire rope Ø4mm, type 7x19<br>coaxial Ø17,2mm (=NPS ¾", 10S)   | max. lateral load: 6Nm = 0.2kg at 3 m<br>max. tensile load: 5kN<br>max. lateral load: 100Nm = 1.67kg at 6 m                     |
| Probe length [L]                          | single rod probe: 100...3.000mm<br>wire rope probe: 1.000...20.000mm<br>coaxial probe, standard application temperature: 100...6.000mm<br>coaxial probe, extended application temperature 100...1.000mm<br>can be ordered in 5mm increments<br>the reference point is always the shoulder of the connection thread   | longer length on request  |
| Inactive area top [I1]                    | single rod probe, ε <sub>r</sub> =80: 50mm<br>wire rope probe, ε <sub>r</sub> =80: 50mm<br>coaxial probe, ε <sub>r</sub> =80: 30mm   | single rod probe, ε <sub>r</sub> =2: 80mm<br>wire rope probe, ε <sub>r</sub> =2: 80mm<br>coaxial probe, ε <sub>r</sub> =2: 50mm |
| Inactive areas bottom [I2]                | single rod probe, ε <sub>r</sub> =80: 10mm<br>wire rope probe, ε <sub>r</sub> =80: 10mm<br>coaxial probe, ε <sub>r</sub> =80: 10mm   | single rod probe, ε <sub>r</sub> =2: 50mm<br>wire rope probe, ε <sub>r</sub> =2: 50mm<br>coaxial probe, ε <sub>r</sub> =2: 50mm |
| Measuring range [M]                       | probe length [L] less both inactive areas at top and bottom [I1 and I2]<br>in this range KFA2 will have the specified measurement performance. It is recommended that the maximum and minimum liquid levels to be measured in the tank are actually within the measuring range [M] of the sensor<br>[default]: 4mA are set at 10mm above probe end, 20mA are set at 50mm below reference point |   |
| Lower [4mA] and upper [20mA] signal level |  |   |
| Switching point [S]                       | freely positionable within the measuring range [M]<br>hysteresis can be set by defining separate upper and lower thresholds; if those are set at the same position, the minimum hysteresis of 3mm applies  |   |
| Hysteresis                                | [default]: switching point is set at 20% of probe length [L], from reference point downwards   |   |

|  |  |                                     |
|--|--|-------------------------------------|
| APPLICATION SPECIFICATIONS                                     | continuous level measurement and point level detection in liquids and light solids   |                                     |
| Dielectric constant [ $\epsilon_r$ ]                           | single rod / wire rope probe: >1,8   | coaxial probe:>1,4                  |
| Conductivity   | no restrictions  |                                     |
| Density  | no restrictions  |                                     |
| Dynamic viscosity  | single rod / wire rope probe: <5.000mPa s = 5.000cP<br>coaxial probe: <500mPa s = 500cP  |                                     |
| Standard application temperature                               | single rod / wire rope probe:  | -40°C...+150°C                      |
|  | single rod probe PTFE coated:  | -15°C...+100°C                      |
|  | coaxial probe EPDM o-ring:   | -40°C...+130°C                      |
|  | coaxial probe FKM (Viton) o-ring:  | -15°C...+150°C                      |
| Extended application temperature<br>single rod / coaxial probe | NBR o-ring:  | -200°C...+250°C                     |
|  | FKM (Viton) o-ring:  | -150°C...+250°C                     |
| Ambient temperature  | operation: -25°C...+80°C   | storage: -40°C...+85°C              |
| Application pressure   | -1bar...40bar, except single rod probe PTFE coated: 0...4bar   |                                     |
| Velocity of level change                                       | <1.000mm/s   |                                     |
| Interface (e.g. oil on top of water)                           | an oil layer of <70mm thickness on top of water is not detected by the sensor; in this case the sensor will detect only the water level at a slightly lower position than actual. From an oil layer thickness >70mm onwards, the sensor detects the total level, including the oil layer, according to specifications  |                                     |
| <b>MECHANICAL SPECIFICATIONS</b>                               |  |                                     |
| Material exposed to<br>tank atmosphere                         | single rod probe, standard application temperature: 1.4404 / 316L, PEEK<br>single rod probe, ext. temp.: 1.4404 / 316L, PEEK, PTFE, o-ring (see order code)<br>single rod probe PTFE coated: PTFE, o-ring (see order code)<br>wire rope probe: 1.4401 / 316, PEEK<br>coaxial probe, std. temperature: 1.4404 / 316L, PEEK, o-ring (see order code)<br>coaxial probe, ext. temp.: 1.4404 / 316L, PEEK, PTFE, o-ring (see order code)<br>gasket at connection thread: Klingersil C-4400, 2mm thick<br>other materials on request   |                                     |
| Materials housing  | housing body and cover: <ul style="list-style-type: none"> <li>aluminium alloy EN AC-ALSi9Cu3 (DIN EN 1706), epoxy spray coating (~70µm)<br/>other alloys and coatings on request</li> <li>stainless steel 1.4401 / 316</li> </ul> cover o-ring: silicone rubber (Elastosil R 750/50)<br>other o-ring materials on request<br>cover safety chain / screws; cover locking screw; nameplate / rivots: 1.4301 / 304<br>external earth terminal / screw: tin plated stainless steel 1.4301 / 304   |                                     |
| Housing rating   | IP68, NEMA6P<br>device cover has to be properly tightened and IP68 screw plugs and cable glands have to be properly mounted (with sealing) and have to be properly tightened around cable of suitable type and diameter<br>the cover has a locking screw (allen key size 1,5mm) and a safety chain to prevent it from falling to the ground after being unscrewed  |                                     |
| Cable entries [D2/ D3]   | 2 cable entries M20x1,5  | other dimensions on request         |
| Cable glands / screw plugs                                     | <ul style="list-style-type: none"> <li>[D2]: cable gland, M20x1,5, IP68, nylon PA66, for non-armoured cable <math>\varnothing</math>5...9mm, with EPDM washer, max. tightening torque 6Nm, wrench size 24mm. For protection during shipment closed with EPDM sealing plug (to be removed for cabling)</li> <li>[D3]: screw plug, IP68, M20x1,5, nylon PA66, with EPDM washer<br/>other cable glands / screw plugs on request</li> <li>[D2] and [D3]: protective plugs, PE-LD, not IP68, only for housing protection during shipment, to be replaced by customer</li> </ul> |                                     |
| Connection thread [CT]   | G $\frac{3}{4}$ A or $\frac{3}{4}$ " NPT (wrench size 32mm)  | other connection threads on request |
| Weight   | aluminium housing (empty): 650g; stainless steel housing (empty): 1.270g<br>electronics: 70g; feedthrough: 220g; single rod probe, 1m: 230g<br>wire rope probe, 1m (no counterweight): 66g; counterweight: 380g<br>coaxial tube (not assembled), 1m: 540g; attachment kit coaxial tube: 130g<br>temperature extension: 900g:   |                                     |

DIMENSIONS IN MM

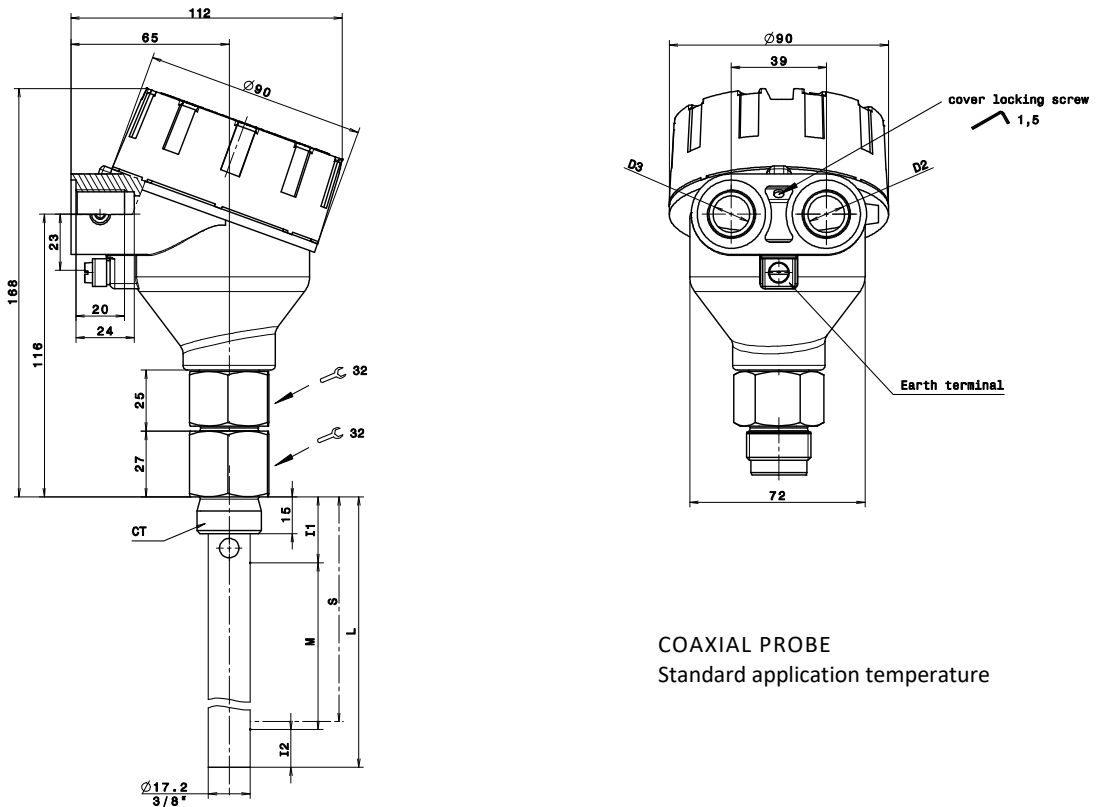
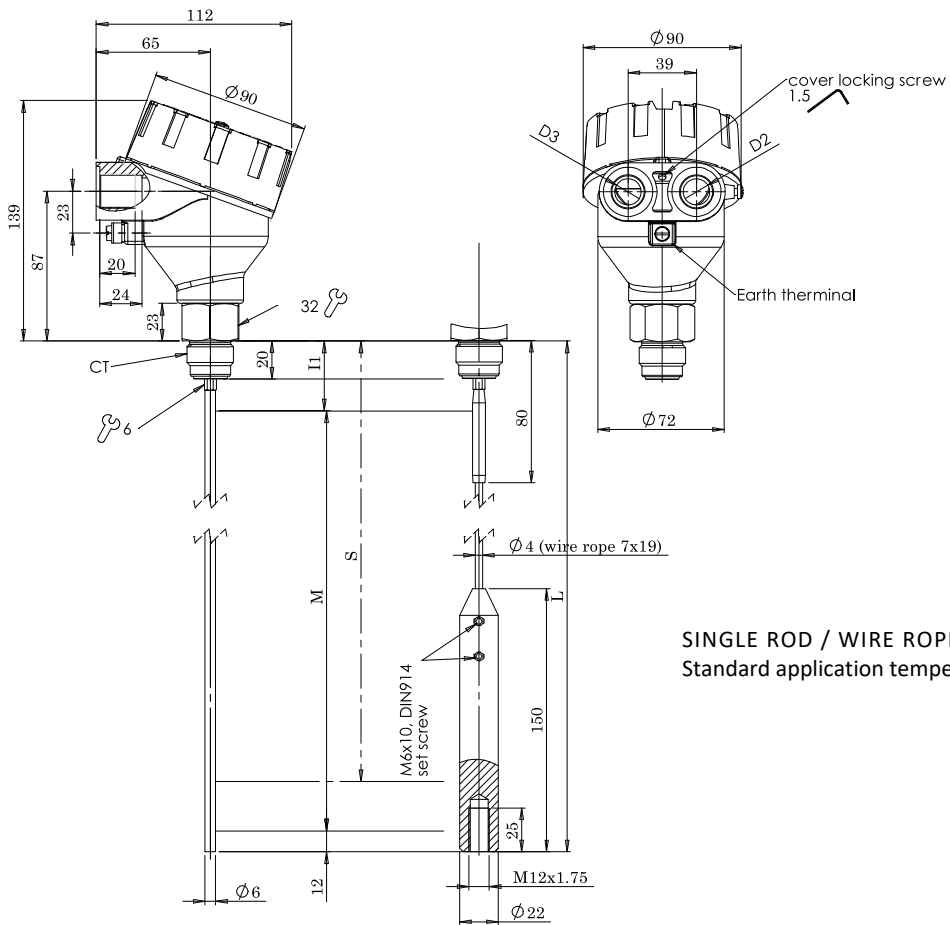

DIMENSIONS IN MM

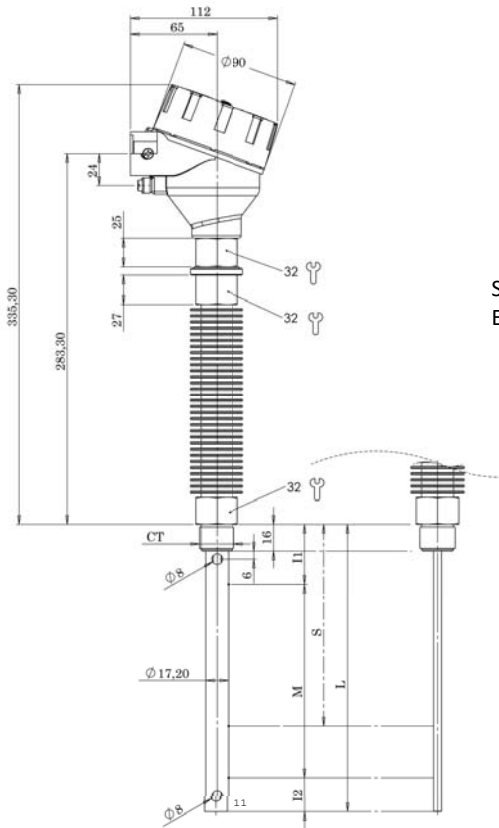

SINGLE ROD / COAXIAL PROBE  
Extended application temperature

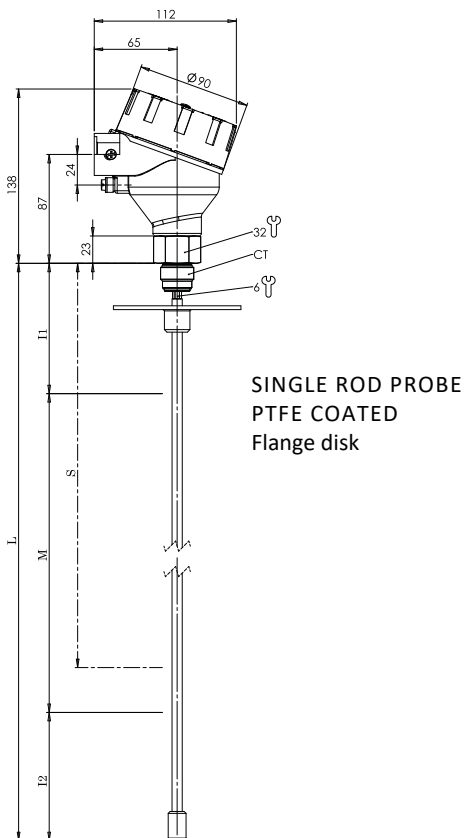

SINGLE ROD PROBE  
PTFE COATED  
Flange disk

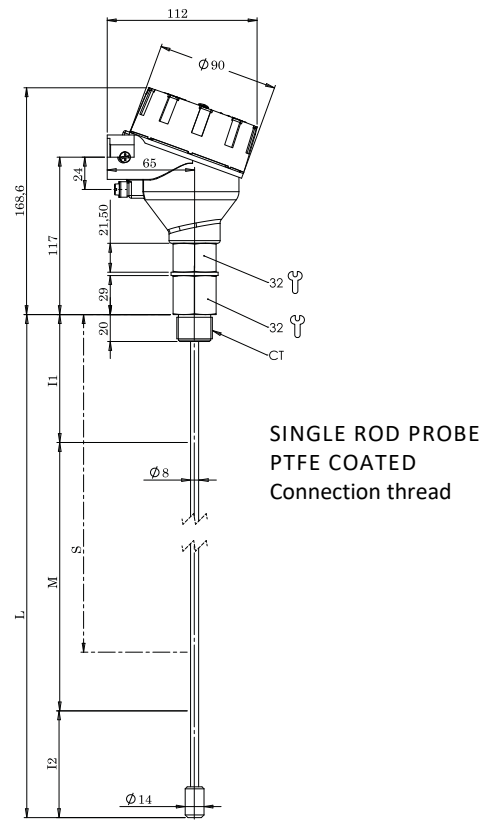

SINGLE ROD PROBE  
PTFE COATED  
Connection thread

